

ADAPTABLE CONSERVATION BOOK SUPPORT (ACBS): Assembly Instructions

To contribute, please contact Roger Williams: roger.shaw.williams.jr@gmail.com

Options for the lower board: A single [maple panel \(part 1\)](#) works fine for the lower board. If a thicker, heavier lower board is desired, two maple panels can be adhered or attached via extra wood screws. A thicker lower board will allow for easier movement of the [lever-lock hinges \(part 3\)](#), and the added weight will help with stability. (There are also options for cradled wood panels, which would provide greater thickness without increased weight.)

1. Attach the [lever-lock hinges \(part 3\)](#) to the [maple panel \(part 1\)](#) base.
 - a. Find the correct position for the hinge mounts on the corners of the [maple panel](#). Use a pencil to mark the locations where the screws will be mounted. (Note: the hinge mounts should sit flush with the edges of the panel. It is vital for the hinges to be properly aligned; be sure all four holes are aligned before drilling.)
 - b. Use the drill (7/64 bit) to create holes for the screws. (Note: to achieve the correct depth, first mark the screw length on the drill bit with a piece of masking tape. Clamps should be used to secure the panel while drilling.)

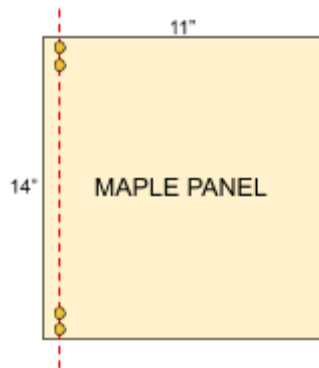

- c. Secure the hinge mounts to the maple panel with the [wood screws \(part 10\)](#) using a screwdriver.
2. Attach the [lever-lock hinges \(part 3\)](#) to the [hardboard panels \(part 2\)](#)
 - a. Find the correct position for the hinge mounts on the corners of one of the two [hardboard panels](#). Use a pencil to mark the locations where the screws will be inserted.
 - b. Use the drill (15/64 bit) to create holes for the screws through **both** hardboards. Position the boards so they are flush before clamping and drilling.
 - c. Secure the hinge mountings to the hardboards with the four [M6 flat head screws \(part 7\)](#) and [M6 end-feed nuts \(part 8\)](#). Make sure the nuts are oriented vertically (perpendicular to the hinge pins).

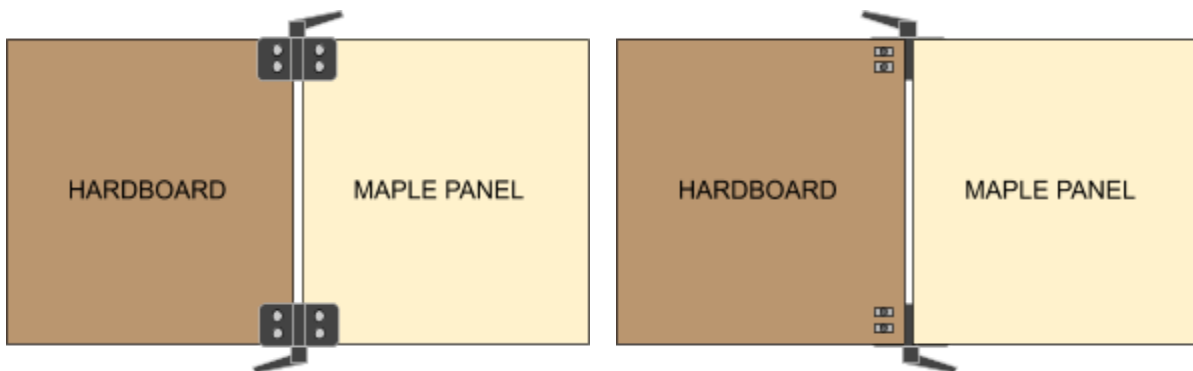

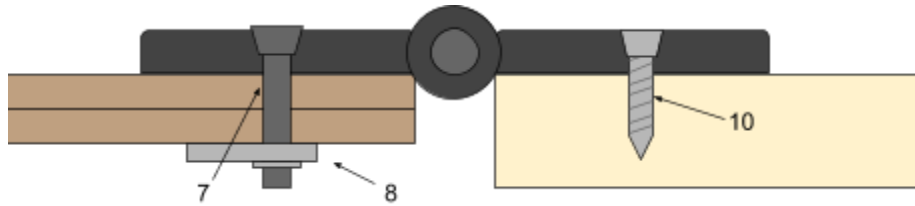

3. Attach the [T-slotted framing \(part 4\)](#) to the [hardboard panels \(part 2\)](#).
 - a. Find the correct position for the [T-slotted profile](#) on the outer, upper edge of the [hardboard panels](#). The [T-slotted framing](#) should sit flush on the edge. Use a pencil to mark the position of the slot on either side of the [hardboards](#)—this should be roughly 0.5" from the edge.
 - b. Using a straight edge, draw a line between the two marks; this line should correspond to the slot that will mount to the sandwiched [hardboards](#). Use a pencil to mark two drilling stations roughly 2" in from the board edges.
 - c. Use the drill (15/64 bit) to create holes for the screws.
 - d. Insert two of the [1/4-20 flanged button head screws \(part 6\)](#) into the holes and loosely thread on two of the corresponding [1/4-20 nuts \(part 6\)](#).
 - e. Slide the [T-slotted framing](#) onto the two exposed [slide-in T-nuts](#). (Note: ensure that the remaining slot is positioned so that it is open on the board edge.) Use the screwdriver to tighten the screws and secure the [T-slotted framing](#) to the [hardboards](#).

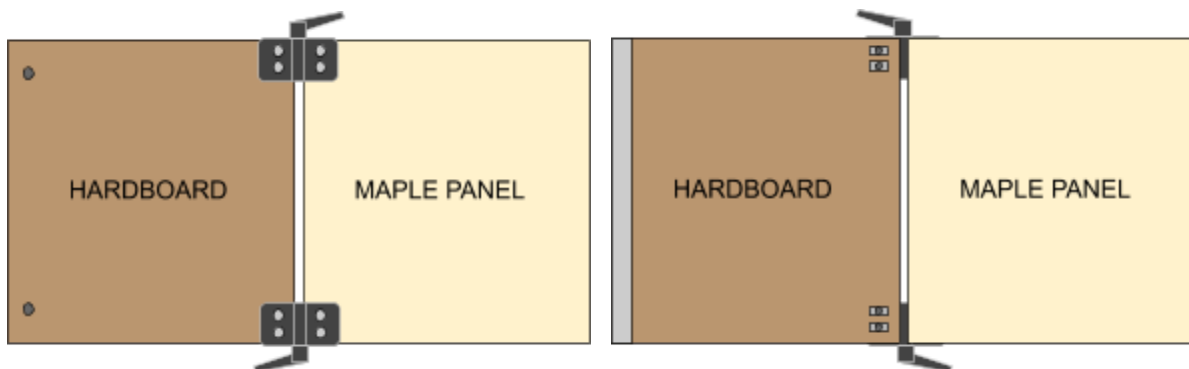
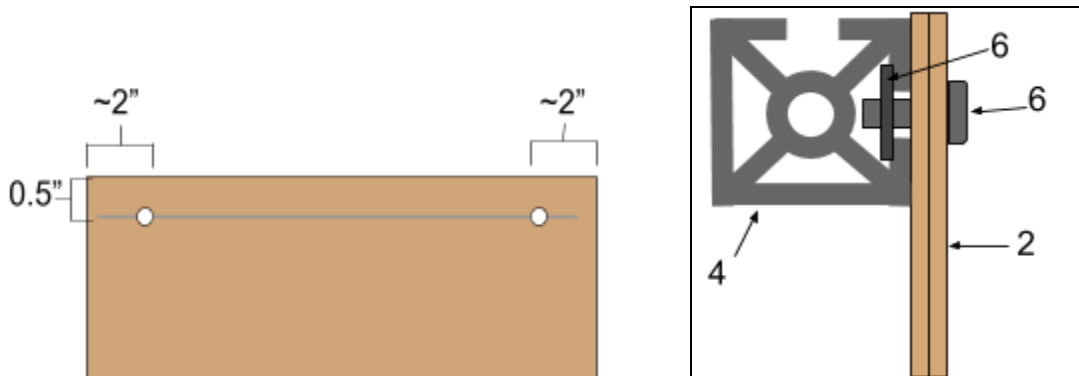

4. Assemble the clamping arms. *(Not required when incorporating the 3D-printed parts.)*
 - a. Cut two pieces of [Coroplast](#) to roughly 3.25" x 2", with the corrugation running parallel to the longer dimension. Attach these to the **short ends** of the [L-Brackets \(part 11\)](#) using two of the

flanged button head socket cap screws and T-nuts (part 6) on each piece of Coroplast. (Note: the Coroplast can simply be stabbed with an awl to create the screw holes.)

- b. Insert two of the plastic-head thumb screws (part 5) into washers (part 9) and then into the slots in the long ends of the L-brackets (part 11), then thread the screws into the two remaining ¼-20 slide in T-nuts (part 9) [Note: you will not be using the remaining two ¼-20 screws]. Slide the T-nuts into the open slot on the T-slotted framing. (Note: the L-brackets should be positioned with their short ends pointed upwards.)
- c. Using the box cutter, cut the fiberglass rod (part 12) into two pieces of roughly 14" in length.
- d. Insert the fiberglass rods into the corrugation of the Coroplast. Attach the corresponding vinyl end caps (part 13) to either end of both rods.

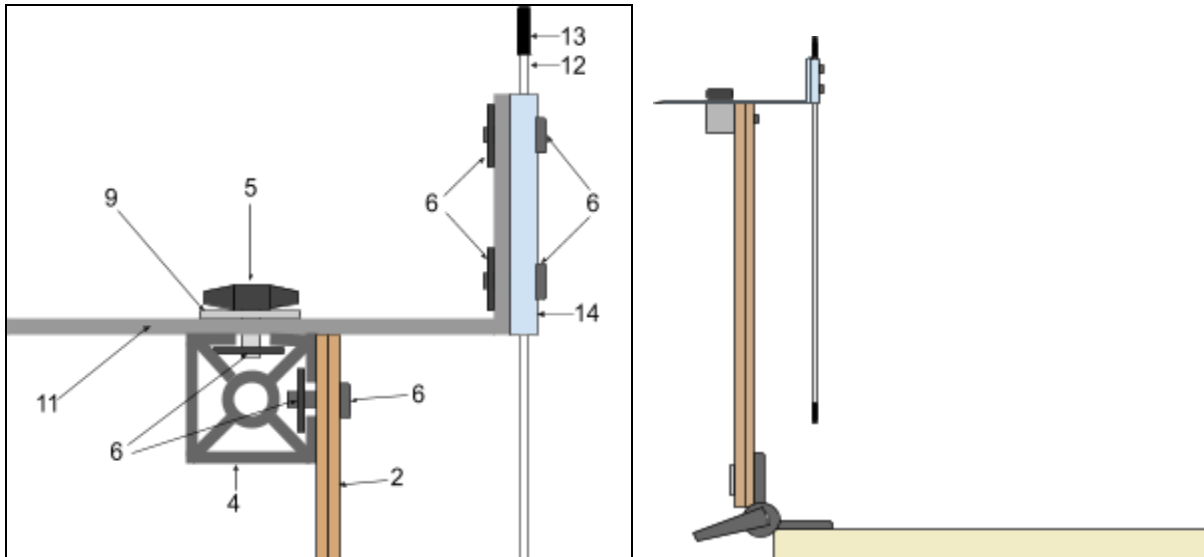

5. Fill and cover (optional)

- a. Use lightweight materials (corrugated board, Volara, Cellu-Cushion, etc.) to bring the thickness of the boards to be flush with the lever-lock hinge mounts. These materials should be measured and cut to shape before being attached with Tyvek tape. Blotter paper can be used as an overall covering material that covers the exposed lever-lock hinge mounts. This will allow the full width of the ACBS to be used.
- b. Tyvek tape can be used to cover all exposed edges of the boards.



CONTRIBUTION HISTORY

The ACBS began in spring 2019 as a collaborative project between the Northwestern University Libraries conservation team and the “Design Thinking & Communication” undergraduate course at the McCormick School of Engineering.

DTC Students, Northwestern University (Evanston, IL, U.S.)

Dylan Clausen
Jonathan Friedman
Aryan Jain
John Kim
Jessica Lee
Deo Mukuralinda
Ariella Silver
Peyton Zona

Northwestern University Libraries Conservation (Evanston, IL, U.S.)

Nicole Dobrowolski (Conservation Technician)
Sara Dohrman (Conservation Technician)
Kimberly Kwan (Conservation Fellow)
Susan Russick (Chief Conservator)
Roger Williams (Book & Paper Conservator)

In summer 2020, a team at the Auckland Museum designed a 3D-printed clamping arm that could be incorporated into the original design. This allows a greater level of adjustability for the clamping rods.

Auckland War Memorial Museum (Auckland, New Zealand)

Heath King (Display Manager)
Erin Walker (Paper Conservator)
Nina Whittaker (Cataloging Librarian)