

## Glossary of Terms Relating to Photo Albums

### BIBLIOGRAPHY

- Frost, Gary. 1984. *A vocabulary of terms for book conservation practice*. New York: Columbia University.
- Gilbert, George. 1976. *Collecting photographica*. New York: Hawthorn Books, Inc.
- Horton, Richard W. 1999. *Historical photo albums and their structures*. Westfield, MA.: Richard W. Horton.
- Horton, Richard W. 2000. *Albums*. Westfield, MA.: Richard W. Horton.
- Rempel, Siegfried. 1979. *The care of black-and-white photographic collections: identification of processes*. Ottawa: Canadian Conservation Institute.
- Roberts, Matt F., and Don Etherington. 1982. *Bookbinding and the conservation of books: a dictionary of descriptive terminology*. Washington: Library of Congress.
- Smith, Merrily A. 1981. *Matting and hinging of works of art on paper*. Washington: Library of Congress.

### GLOSSARY

- album.** An album is a book form mounting one specific type of flat object, such as photos, postcards, stamps, or phonograph records. In early photo albums and some handmade modern albums, there's an attempt to provide generous, or at least uniform, margins. This distancing of one image from another encourages the focused study of each image in its own right, thus raising its value for the viewer. Many but not all albums employ book forms designed to mount photos (or stamps, etc.). Some are further modified to mount specific photo processes such as carte-de-visite or post cards. Others, while still definable as albums, use ad hoc book forms such as unstubbed blank books, sketch-books, or writing tablets (Horton).
- album paper.** "A type of cover [cover-weight?] paper used for photograph albums. It is manufactured in gray and black in basis weights of 50 to 80 pounds (20 x 26 - 500). A basic requirement of this paper is that it not cockle when wetted with adhesives, while another essential requirement is that it contain no impurities which might alter or damage the photographs" (Roberts & Etherington).
- albumen print.** A print made on a thin, albumen-coated paper. The process of printing onto albumen paper was announced in 1850 in France. Albumen prints were made from 1850 to 1900. At first, the thin albumen prints were pasted directly onto album pages. In 1854 they began to be sold already mounted on card, in carte-de-visite size, and, later, in cabinet photo size (Horton).
- back board.** "The part of a mat, made from a solid piece of mat board, that functions as a protective support for the art work" (Smith).
- bond strength.** "The unit load, applied in tension, compression, flexure, peel, cleavage, or sheer, required to break two adhered materials, with failure occurring in or near the plane of the bond. The bond strength of adhesives used in archival work should be such that stress to the point of failure will result in failure of the adhesive, rather than either adherend" (Roberts & Etherington).
- buffered** (refers to paper or paperboard). Sized or coated with an alkaline solution (Horton).
- calotype.** Also called a Talbotype. A calotype involves making a negative on light-sensitive paper in a camera, and then contact printing it onto a second sheet, often waxed or oiled. Calotypes were made from 1841 to 1855 (Horton).
- cabinet photo.** A photographic print, usually albumen, mounted on a 4½" x 6½" card. Introduced in the U. S. in 1866. Stored in a drawer or in a special patented album (Horton).
- carbon print.** A photographic print created by exposing a negative onto a special carbon (in gelatin) tissue; a water wash removes soluble gelatin to leave an image of vary-

ing depth and detail. Carbon prints were made from 1864 to 1900 (Horton).

**carte-de-visite.** A photographic print, usually albumen, mounted on a 4 1/2" x 2 1/2" card. Introduced in Europe in 1854, in the U. S. ca. 1859. Cartes were stored either in a drawer or in a specially designed carte-de-visite album (Horton).

**carte-de-visite album.** An album within a broad spectrum of commercially manufactured album structures designed to mount stiff photo cards non-adhesively in chambers hollowed out of the album leaves (Horton).

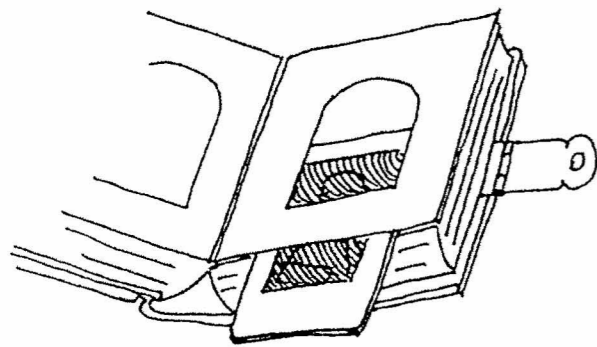

Carte-de-visite album.

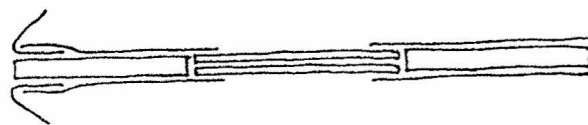

Carte-de-visite album cross section.

**Chicago posts.** "Metal screw posts having two heads, one fastened to a full length post, which is drilled and tapped with a thread, the other attached to a shorter post, which is threaded to be inserted in the main post. The purpose of such posts is to allow additional sheets to be added to the book" (Roberts & Etherington).

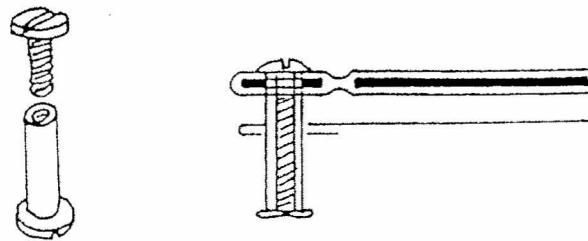

Screw posts.

**cockling.** A wavy distortion in paper or paperboard, caused by uneven expansion (Horton).

**concertina guard.** "A continuously pleated . . . sheet

wrapping the outer folds of the sections." (Frost)

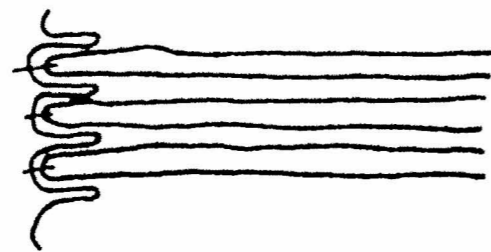

Concertina guard.

**cyanotype.** "A print made from a process developed by Sir John Herschel (1792-1871) using a sensitized material based on ferrocyanate of potassium, first announced in June 1842 . . ." (Gilbert). Cyanotypes are blue in color. Development involves exposure of the sensitized material to sunlight (Horton).

**draw.** "Bowing of the plane of a laminate due to the unequal contraction of the outer layers. Bowing of a board concave to the text can be referred to as positive draw, while bowing of a board convex to the text can be referred to as negative draw" (Frost).

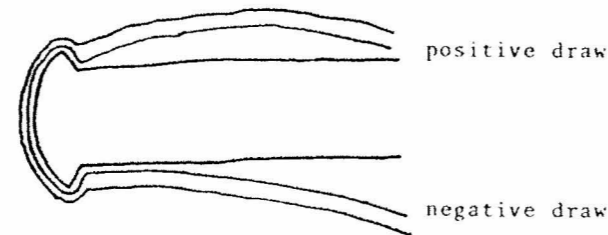

Draw.

**emulsion.** "A coating of light-sensitive material, for example silver salts, suspended in a medium and coated upon a support layer" (Rempel).

**faced.** Lined with a surface layer of paper, often of a more pleasing shade or texture than the substrate (Horton).

**facing.** Referring to album leaf orientation, facing leaf surfaces swing into direct contact when the album is closed. Photos that face one another in an album run the risk of mutual image transference, abrasion, or adhesion (Horton).

**fail/free.** "An expression referring to a repair or a bridging with new material which will act to provide security and motion between original components but which will mechanically fail and detach without damage to the original components. For example, a board re-hinging repair should fail/free of adjoining printed leaves" (Frost).

**ferrotype.** See *tintype*.

**ferrotyping.** "A gloss imparted to an art work by contact with a very smooth surface, especially if pressure or friction is present" (Smith).

**filling in.** "The operation of pasting heavy paper to the insides of the boards of a book within the turn-ins of the covering material. The purpose of filling in is to prevent the thickness of the turn-ins from being noticeable under the board papers" (Roberts & Etherington). It also prevents the edges of the cover from being thicker than the middle, leading to a situation where pressing causes the texture or grain of the covering material to become flattened around the edges. In addition to that, it helps to counteract negative draw. Thus it has many applications to album-making (Horton).

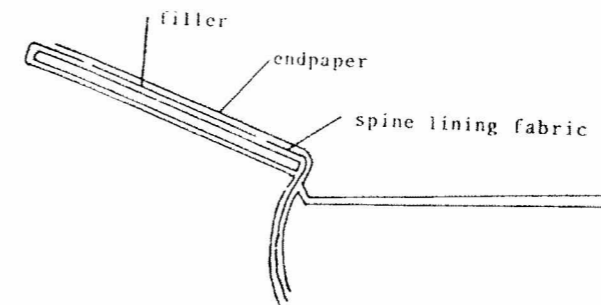

Filling in.

**float.** *v.* "To secure an art work in a mat so that all the edges of the item can be seen through the window opening" (Smith).

**folio, or bifolio.** "A sheet folded once; the two-leaf, four-page unit of a book" (Frost).

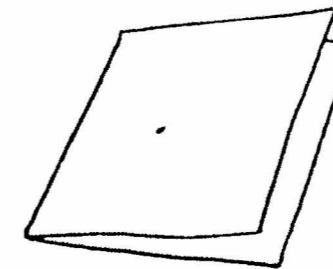

Folio.

**free guard.** "A stub tipped to one component and wrapped around or tipped to another" (Frost).



Free guard.

**gelatin emulsion.** "A coated, light-sensitive layer in

which the medium is a natural protein colloid" (Rempel).

**glassine.** "A thin, dense, smooth-surfaced semitransparent paper" (Smith). Glassine was put over plate images in nineteenth-century books to protect the images from abrasion and to slow the process of image transference, or "burn," onto the facing page (Horton).

**glue.** "A protein-based adhesive" (Smith).

**grain.** "The direction in which most of the fibers in a piece of paper are oriented, and the axis along which the paper tears and flexes most easily" (Smith).

**guard.** A strip of cloth or paper wrapped around a folio at its fold for one of two purposes: to strengthen it, as in the case of an endleaf folio, or to add thickness at the gutter to match the thickness of items mounted on the leaves. See *concertina guard* and *returning guard*. The terms *guard* and *stub* are sometimes used to mean the same thing (Horton).



Guarding.

**guard book.** A book whose leaves turn on cloth hinges, stubs, wings, or guards. Albums with inflexible leaves are given cloth gutter hinges or guards to provide a break point to facilitate leaf turning. The cloth guard also adds thickness at the spine to match the thickness of items mounted on the leaves. While a carte-de-visite album can be classified as a kind of guard book, the name *guard book* as a defining title is more aptly given to a book that mounts things on the leaf surface, not in a recessed compartment in the leaf. Guard books may also be made with flexible leaves, in which case the guarding arrangement serves solely to broaden the spine to match the bulk of things mounted on the leaves (Horton).

**gum bichromate print.** A photograph created by the gum bichromate process, which gave the photographer-artist an opportunity for handwork to alter tonality, omit detail, and reproduce effects akin to paintings or drawings. Gum bichromate prints were produced from 1894 to 1930 (Horton).

**gutter.** "The margin of book components at the binding edge" (Frost).

**hinges.** (1) "Flexible paper strips that attach the art work to its mat along one edge, allowing it to be lifted for

inspection of its verso" (Smith); (2) "Material, usually gummed cloth tape, that joins the window board to the backboard of a mat along one edge, thereby permitting the window board to be opened" (Smith); (3) Wings, guards, or stubs that help to attach inflexible leaves together to form a book (Horton).

**joint.** "The external flexing position in the binding cover" (Frost).

**lamination.** "A composite made of multiple sheets bonded together overall with thermoplastic bond or adhesive bond using a press" (Frost).

**mat.** "A protective housing for flat art works, usually consisting of two boards hinged together along one edge. In general, one board is solid (for support) and the other has a window cut in it (for viewing)" (Smith).

**mechanical mount.** A mount holding a print to an album leaf without adhesive (Horton). See also *non-adhesive mount*.

**meeting guards.** Perfected in the 1880s for ledgers which had to lie open flat, meeting guards allow easy album leaf opening, throwing the gutter up into a plane with the rest of the leaf. The process does, however, require twice the sewing. Leaf sections are discreetly sewed to the peaks of a concertina guard. The valleys of the concertina guard are then sewed together on tapes. Old timers probably have a trick for doing the sewing quickly and getting it tight (Horton).

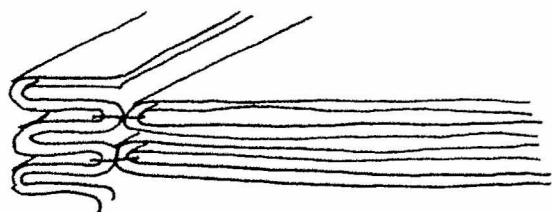

Meeting guards.

**metallic support.** "A base support of metal which maintains a photographic image" (Rempel).

**mount.** "A rigid, unfoldable support of card stock or mat board onto which a print or map is bonded. The object may be laminated, perimeter bonded, tipped or hinged" (Frost).

**mounting compartment.** A hollow chamber inside a carte-de-visite album leaf designed to hold cartes-de-visite or cabinet cards in viewing windows (Horton).

**mounting corners.** A non-adhesive mounting device that consists of photo corner holsters, usually triangular in shape, made of paper or plastic. The mounting corners themselves are adhered to the leaf surface (Horton).

**mounting slits.** A non-adhesive mounting device that consists of a set of slits cut through the leaf where the corners of the photo may be tucked, lodging the photo

in place. (Horton)

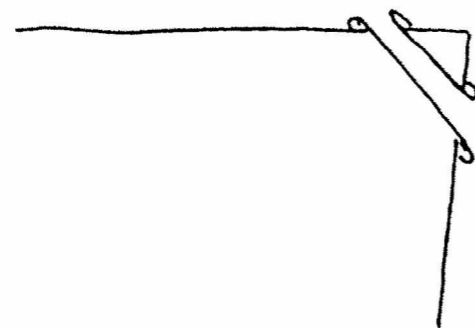

Mounting slits.

**non-adhesive.** "Mechanical attachment without adhesive bonding, consolidation, or lamination" (Frost).

**non-adhesive mount.** A mount holding a print to an album leaf without adhesive (Horton). See also *mechanical mount*.

**paper support.** "A layer of paper onto which a light-sensitive emulsion is coated. Paper supports show the largest variety of types of photographic artifacts" (Rempel).

**paste.** "An adhesive composition with semisolid consistency, usually water dispersible. Pastes most commonly used in conservation work at the Library of Congress are cooked wheat or rice starch" (Smith).

**Platinotype.** Process invented in 1859, patented in England in 1873. Papers were commercially made by the Platinotype Company after 1879. The process was in vogue from 1879 to 1900 and produced a photographic print of great permanence characterized by delicate tones and rich blacks with an overall silver-gray color. The process uses platinum within the sensitized materials (Horton).

**polyester film.** "A thin, transparent, flexible plastic sheeting made from polyethylene terephthalate and sold under a variety of trade names. When uncoated and untreated with other materials, it is smooth and exceptionally stable" (Smith).

**post card album.** This is a historical album structure occurring from 1910 to 1920. Sections, quires, or signatures of thick paper are sewed on a single or two-ply concertina guard of the same paper, creating extra thickness at the spine to match the anticipated thickness of the post cards which will be mounted. Sewing is accomplished by metal stitches (staples) applied from the inside of the section, such that the staple ends close on the outside of the spine, embracing a canvas spine liner. Post card corners are inserted in mounting slits punched through the leaves (Horton).

**recto.** "The front side of a leaf of paper" (Smith).

**returning guard.** A guard formed by the turning-over of

the gutter edge of the leaf or its stub, hinge, or wing (term suggested by Bernard Middleton).

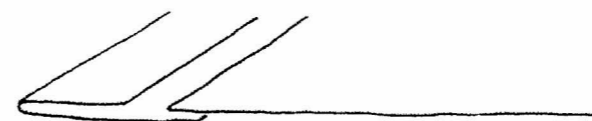

Returning guard.

**scrapbook.** A scrapbook is a book form intended for multi-media, all-purpose mounting. Scrapbooks, as even the name suggests, have always invited casualness. Uniform margins are seldom maintained; compilers generally load the pages to capacity and beyond, to the dismay of many a conservator confronted with overstuffed volumes with protruding contents. The most common book form used as a scrapbook is a stack of turn-stubbed singleton leaves sandwiched between two grooved panel covers, this book block being side-drilled near the spine and laced or posted. It's tempting to call the book form in itself a scrapbook, but one should wait till one sees the word "Scrapbook" stamped on the cover, or sees the jumble of diverse contents or clippings, that indicate the book form has in fact been used as a scrapbook, because this book form was also the major *album* structure from 1920 to 1960. Other book forms, such as through-the-fold-sewed books with wrap-around stubs, were used as scrapbooks too. The cover, though sometimes extravagantly embossed and stamped in several colors, was generally of cheap materials, and scrapbook paper is notorious for its acidity. This once again points to the casual nature of scrapbooking (Horton).

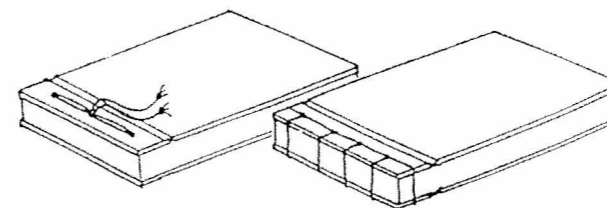

Scrapbooks.

**section.** "... the folded sheet unit which is sewn with oth-



Section.

ers into a text block" (Frost). Also called *quire*, *gathering* or *signature*.

**sheet.** "... the unfolded piece of paper" (Frost).

**shoulder.** "A margin of the gutter on either side of a text block which is deflected outward at an angle to the plane of the pages to accommodate swelling and provide a seat for boards or case construction joints" (Frost).

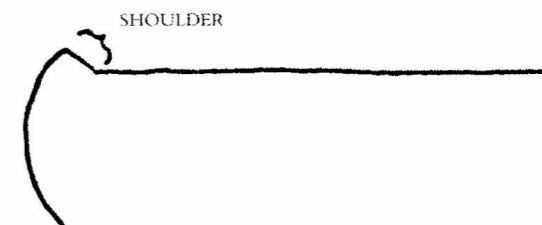

Shoulder.

**side sewing.** "Sewing through the page plane at the gutter margin" (Frost).

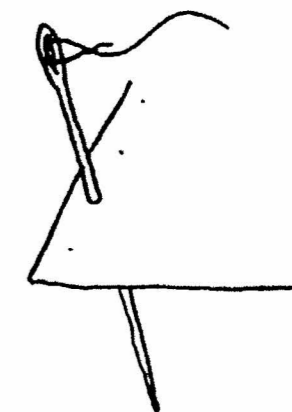

Side sewing.

**sized.** Coated or impregnated with sizing.

**sizing.** A substance, either gelatin or starch, with which paper fibers are impregnated, to reduce their ability to absorb liquids. Writing or printing ink will sit on the surface, rather than feathering (dispersing rapidly into the fibers), when a paper is sized (Horton).

**sleeve, Mylar.** A clear plastic film envelope to hold a photo print, protecting it. Mylar is a trade name for one type of clear polyester film. Sleeves may be open on one, two, or three sides. To avoid trapping possible degradation products, I use mounting sleeves open on three sides. These also allow the print to be put into

the sleeve without a dangerous amount of pushing and sliding (Horton).



Mylar sleeve.

**snapshot.** An early silver gelatin print from the era 1885-1920. Snapshots differed from later silver gelatin prints in that they were printed on thin paper, and had a brownish tone and a semi-gloss surface, sometimes looking a little like albumen prints. One often sees early snapshots with a circular image area.

**snapshot album.** An album made for snapshots, and for the snapshot era, from 1900 to 1920. The leaves feature a substrate faced with dark, thick paper with viewing windows. The snapshots are inserted from the edge of the leaf, pushed between the facing paper and the substrate, and moved toward the windows where they are centered beneath the cutout. The facing paper, sparsely tacked to the substrate, hugs the snapshots in their places (Horton).

**stay.** "A reinforcement of vellum or leather seated in the inner folio fold to strengthen the stitch stations and secure the text folios" (Frost).



Stay.

**stub.** "A paper extension tipped to the gutter edge of a plate, leaf, or map which provides a margin for binding or attachment (see also *wing*)" (Frost). In library bindery parlance, a stub is a strip of paper or cloth tipped to the gutter edge of a leaf to match the thickness of a flat

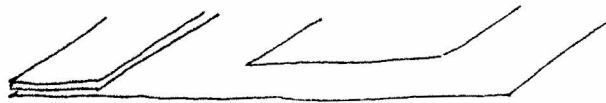

Free stubs.

object, such as a photo or map, mounted to the leaf. Several strips of stubbing may be needed if the mounted object is thick. Using this definition, compensatory thickening of the leaf at the gutter may be achieved by (1) attaching free stubs, or (2) making a fold in the gutter edge of the leaf, the hinge, or the wing, to produce a flap which acts as a stub (Horton). See also *guard*, *returning guard*.

**substrate.** The layer of paperboard beneath the external layers of paper with which some album leaves are faced (Horton).

**support.** "The paper, card, vellum, fabric, or other material on which the design layer or image is executed" (Smith).

**swing.** "The gutter margin for flexibility provided by stubs attached to non-pliant leaves" (Frost).

**tack.** "Attachment between components by a spot of adhesive" (Frost).

**thread mounting.** Seen on early Japanese photo albums, this mounting method involves tying the corners of the photos to the page with silk thread. The leaf is typically a concertina fold either of paper or some decorative composite. At any rate, it has an outside and an inside surface. The thread ends are tied off on the inside surface, hidden away from view (Horton).

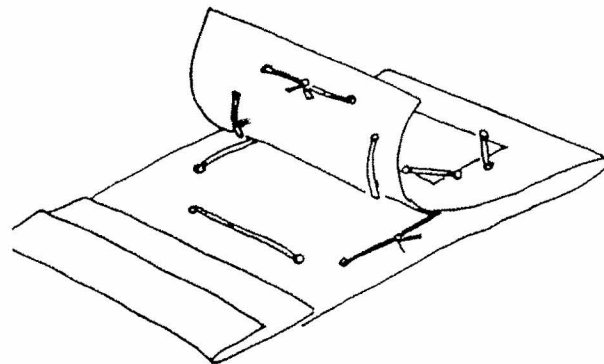

Thread mounting.

**tintype.** A direct positive (negativeless) photograph on a thin iron sheet developed by a French process of 1853. Introduced to America beginning in 1860, its excellent tonal range, durability, and low cost made it a popular process into the 1930s.

**tip.** "A narrow adhesive seam bond between sheets" (Frost).

**turn stub.** See *returning guard*.

**verso.** "The back side of a leaf of paper" (Smith).

**window board.** "A piece of board in a mat in which an opening is cut to allow the art work to be displayed" (Smith).

**window opening.** The aperture in the window board.

**wing.** "A paper extension tipped to the gutter edge of a plate, leaf or map which provides a margin for binding or attachment" (Frost). See also *stub*, *hinge*.

#### CREDIT

This glossary, here revised and updated, was originally published by the author in *Historical photo albums and their structures* (Westfield, MA: Richard W. Horton, 1999). Illustrations by the author.

RICHARD W. HORTON  
Westfield, Massachusetts