

Fold-together box instructions

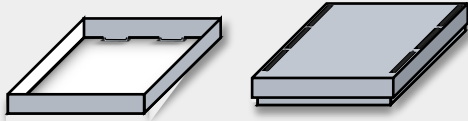

by Chloe Gise

September 2020

TRAY:

1. Mark the Height, Width, and Length of the object on a strip of paper*.
2. On a piece of single-layer corrugated board, use the strip to mark measurements for the tray of the box.
3. Using a board creaser, crease each mark as indicated by the **dotted** lines**.

Tip: Use a board "jig" to help mark board thickness

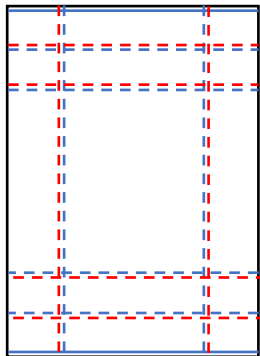

**For an accurate fit, crease to the ends of the board. Do not crease exactly on the marks made, but slightly outside of them. This is so the interior of the box does not get smaller as you crease. For example, on the left side, crease slightly left of each mark. Repeat with the right side, creasing slightly to the right of the mark.

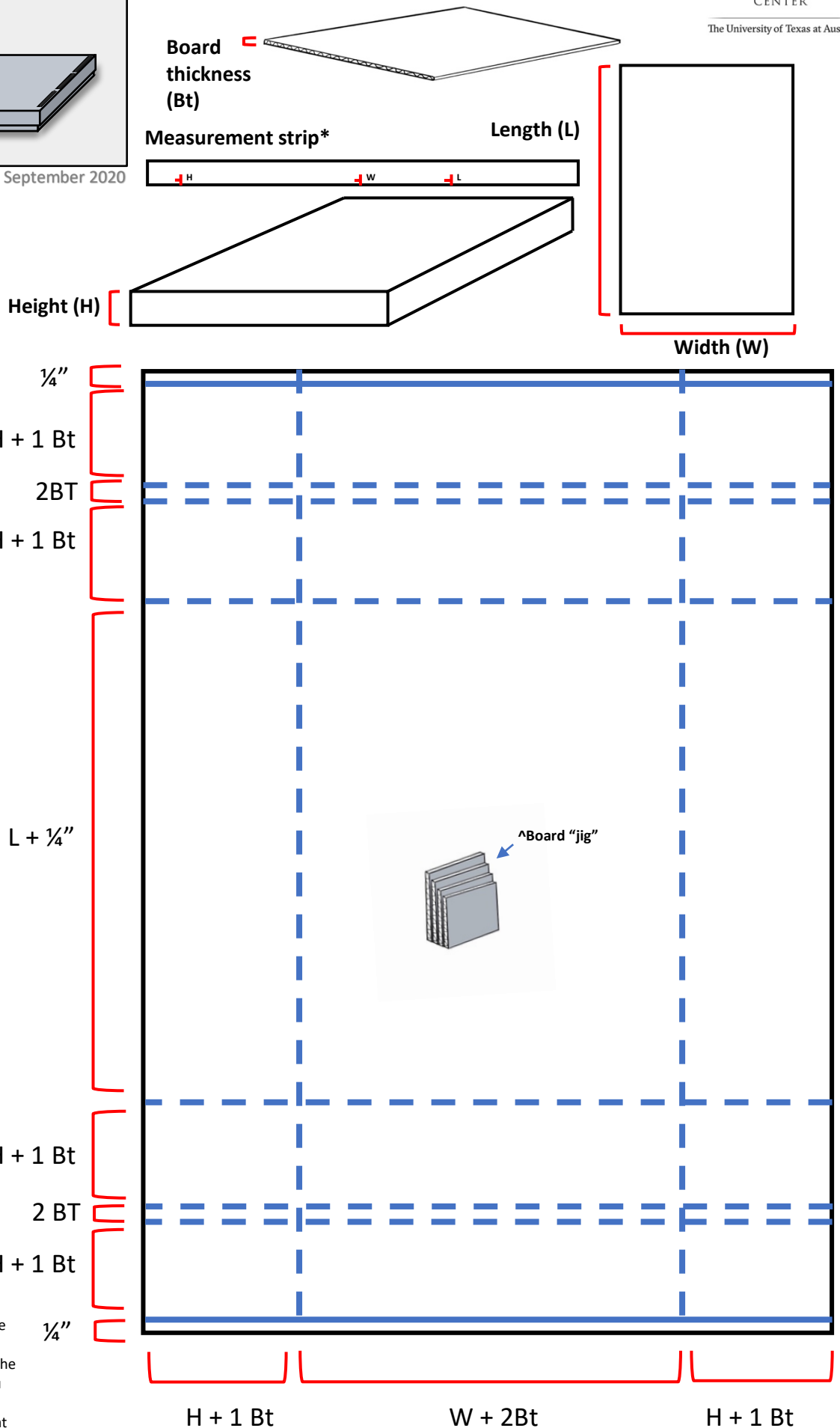

4. Turn the board over and cut away the 4 "hills" as indicated.

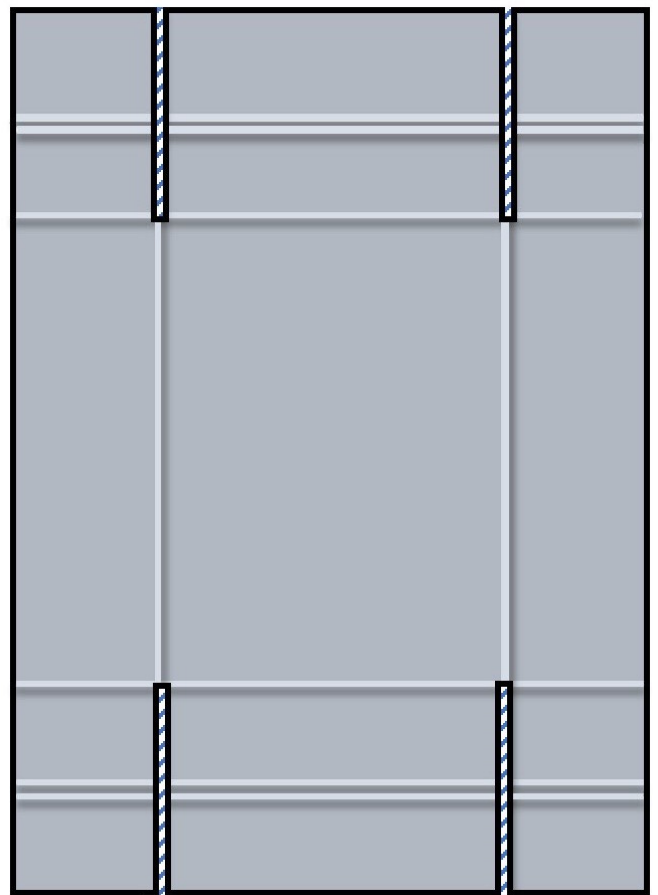
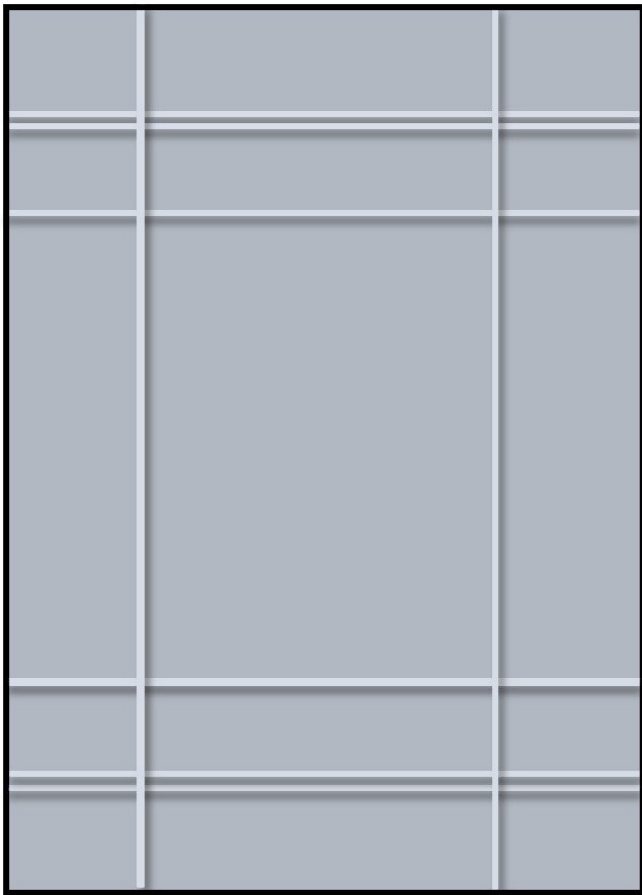

5. Find the center of the center top and bottom shapes. Cut two tabs evenly spaced and 1/4" long.

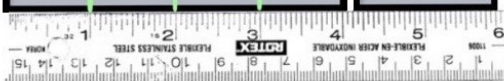
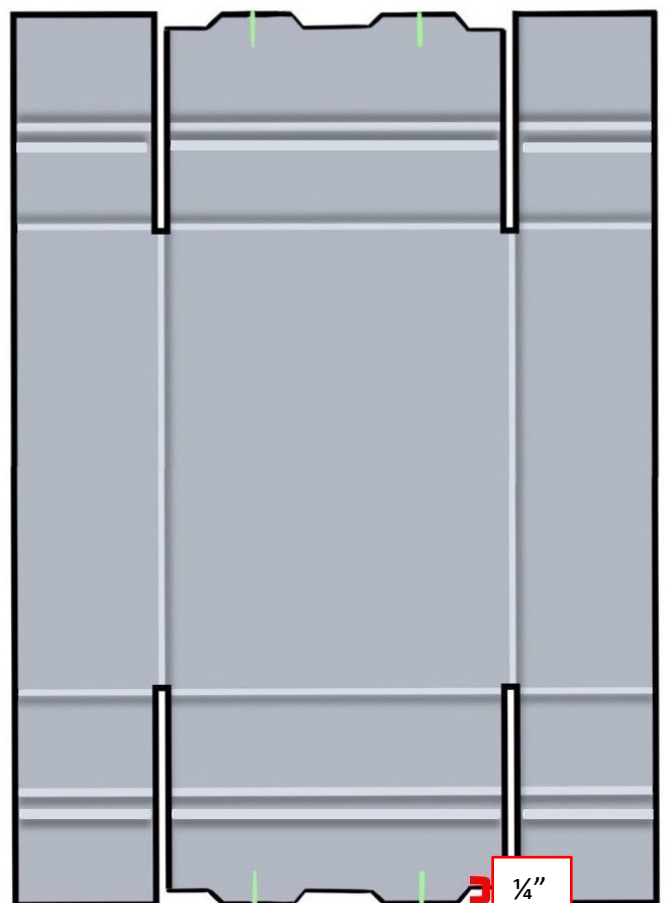
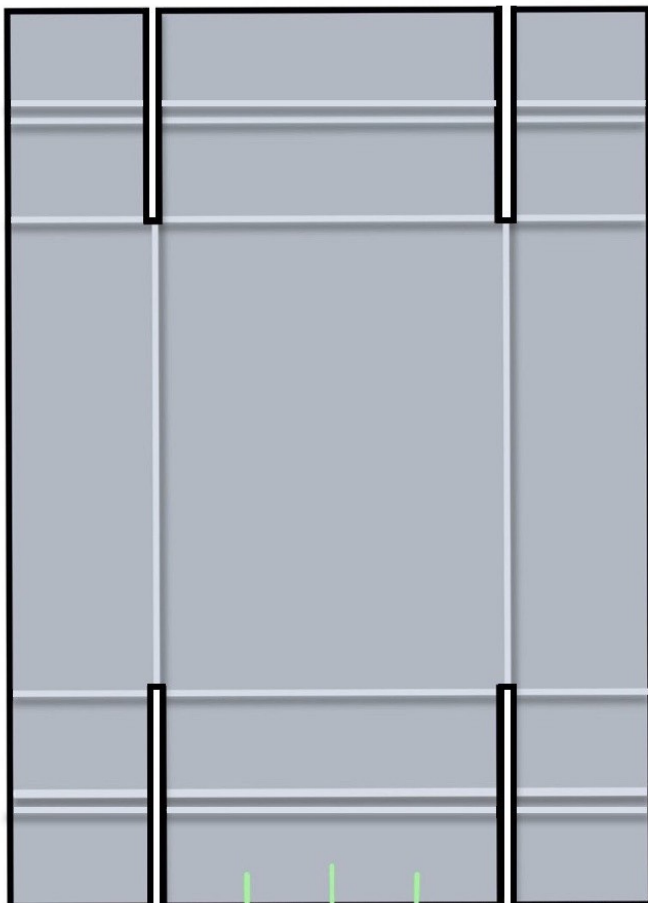

6. Fold the tabbed end over and mark the width of the tabs. This indicates the width of the slots to be cut out later. Repeat for the other side.

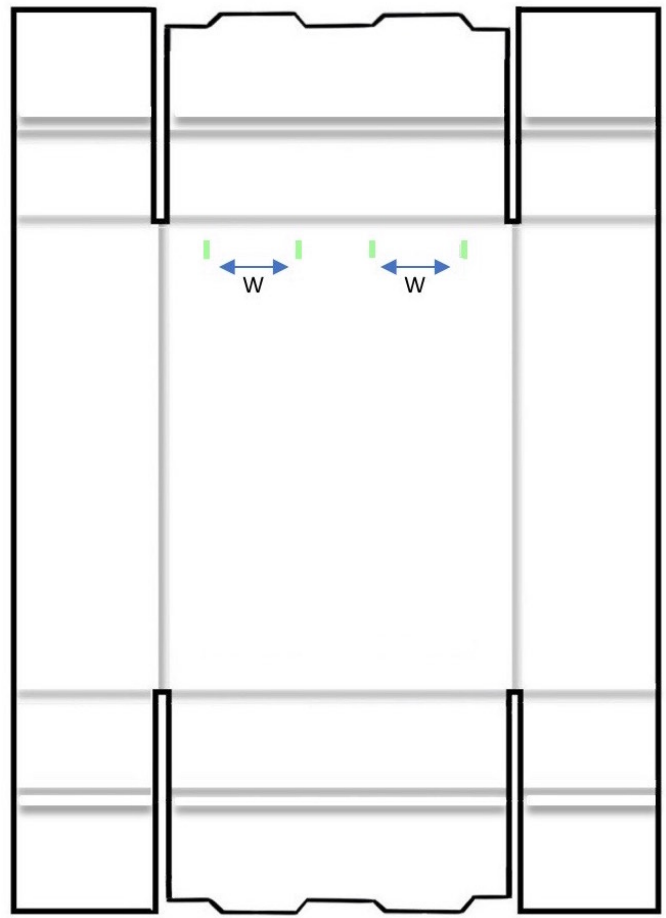
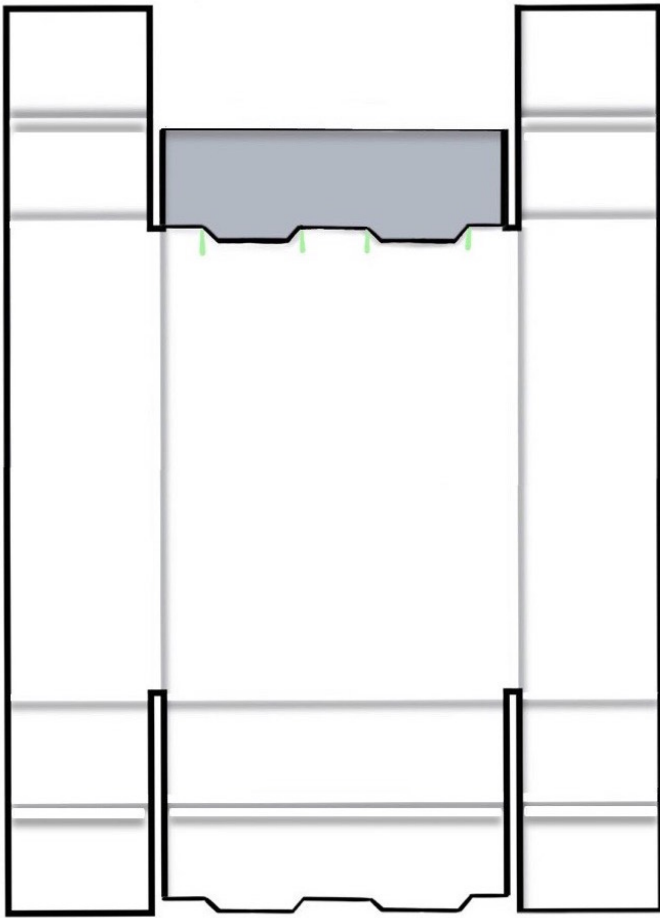

7. Use the board jig to mark two board thicknesses from the crease. The slot you cut out should be one board thickness thick. See image.

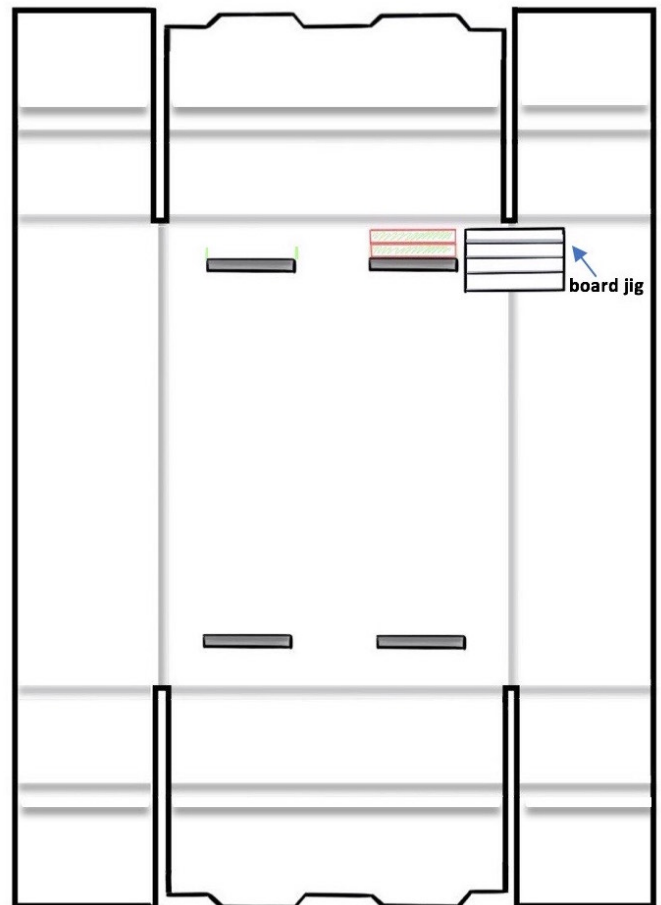

8. Fold over the left and right sides. The long edges will be tucked inside the top and bottom folds. Trim if they are too long. Fold the top and bottom pieces over the long edges and into the tabs.

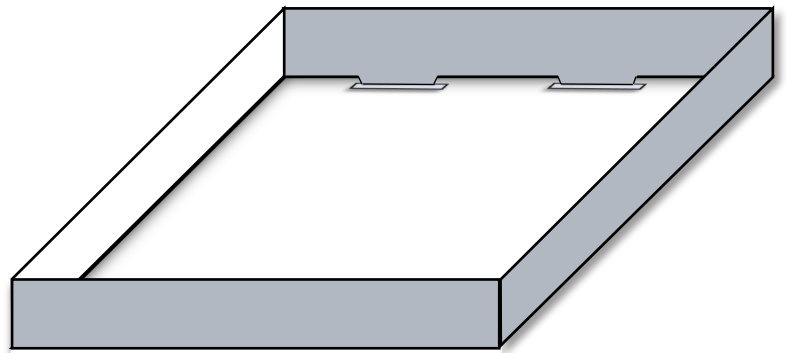
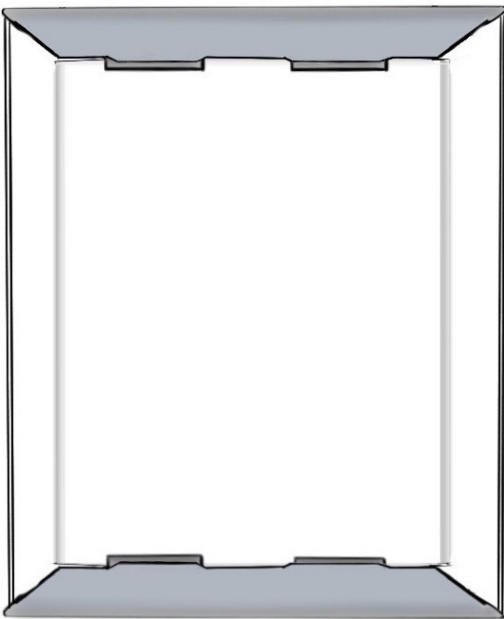
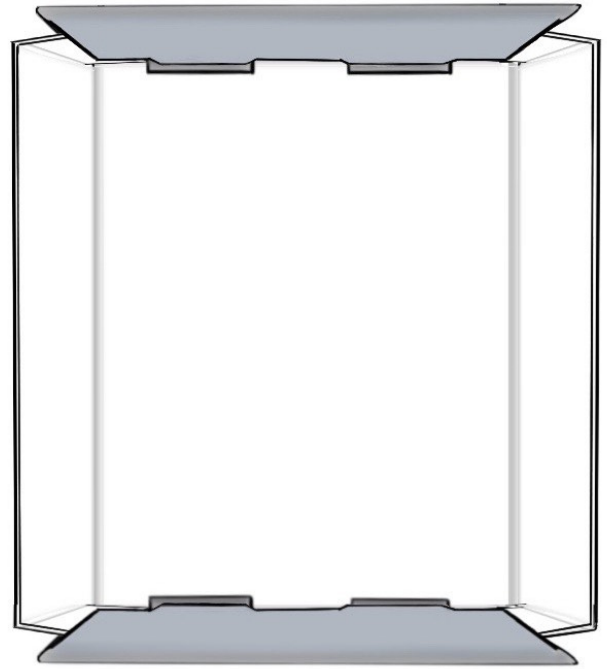
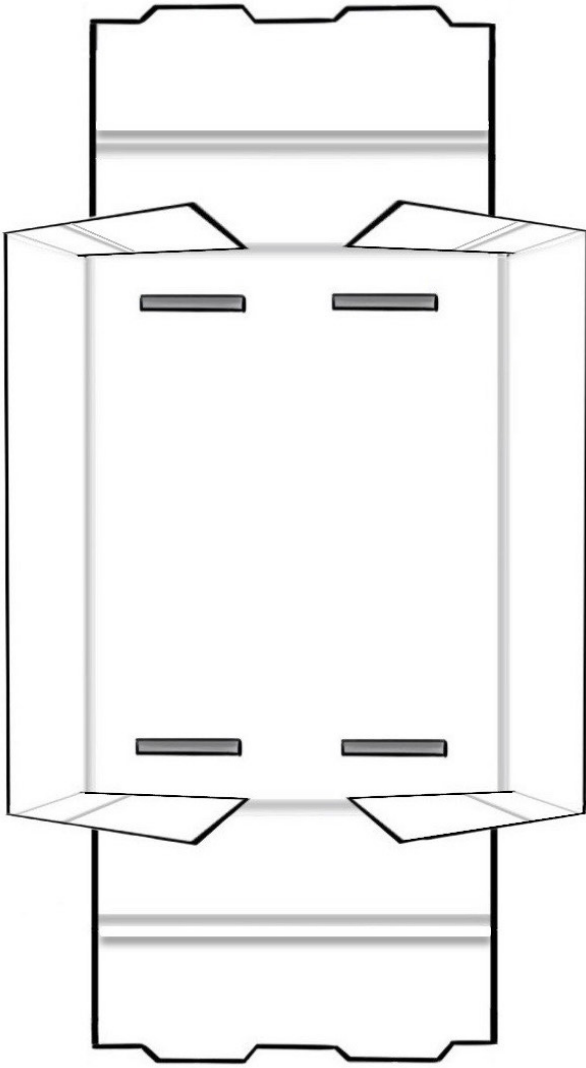

LID:

1. On a separate piece of single-layer corrugated board, use the completed tray to mark measurements for the width and length of the lid instead of the measurement strip. Use the original height of the object to mark the height. This provides the lid with a more accurate fit and becomes slightly shorter for easier opening.

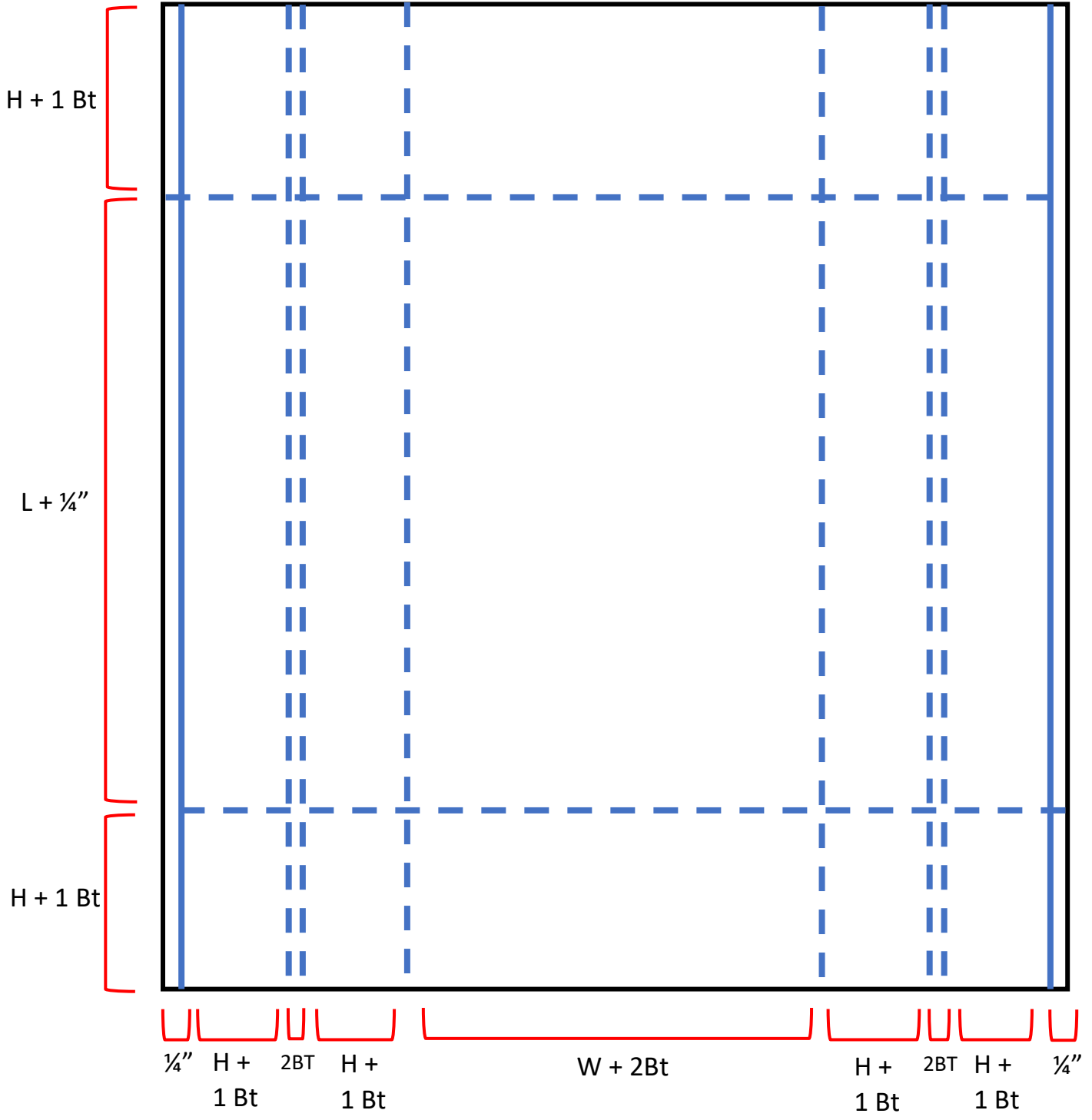
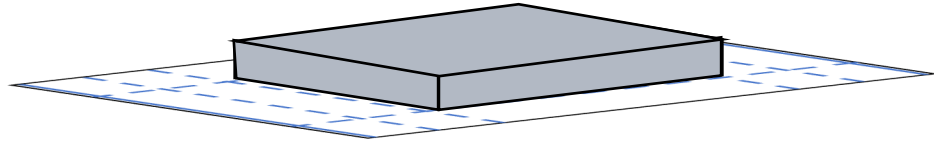

2. Turn the board over and cut away the 4 “hills” created as indicated.

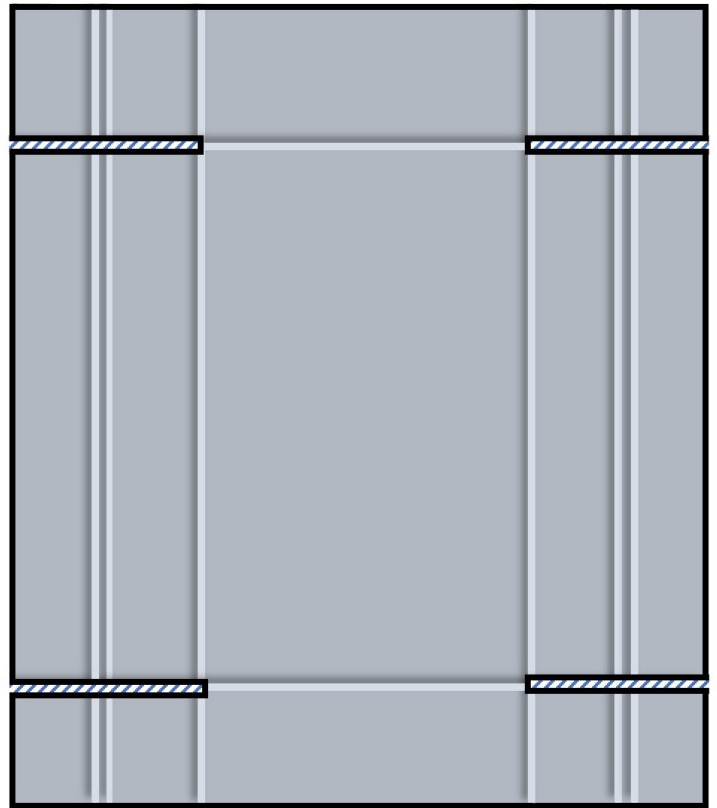

3. Find the center of the longest right and left center edges. Cut **three** tabs evenly spaced and $\frac{1}{4}$ " long.



Note: Three tabs help provide support if the sides are long. If the box is small, only two tabs are needed to prevent overcrowding.

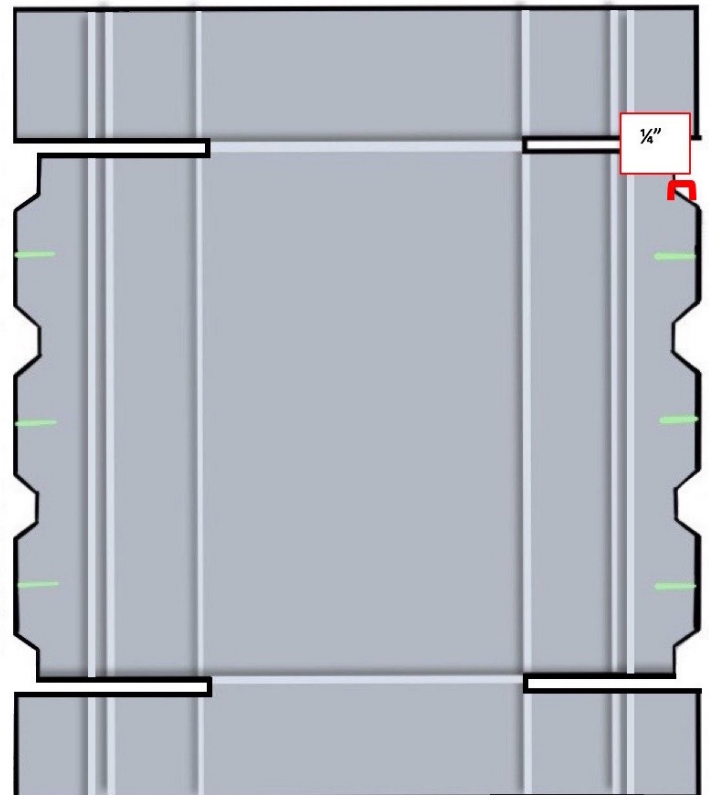
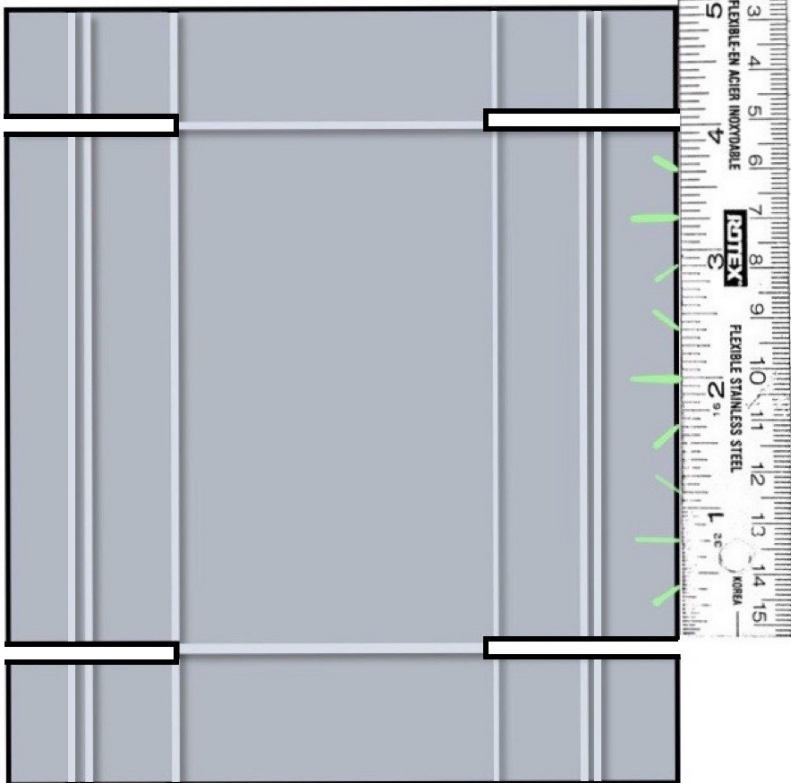

4. Fold the tabbed side over and mark the width of the tabs. Repeat measurements on step #6 on the tray instructions when cutting out these slots.

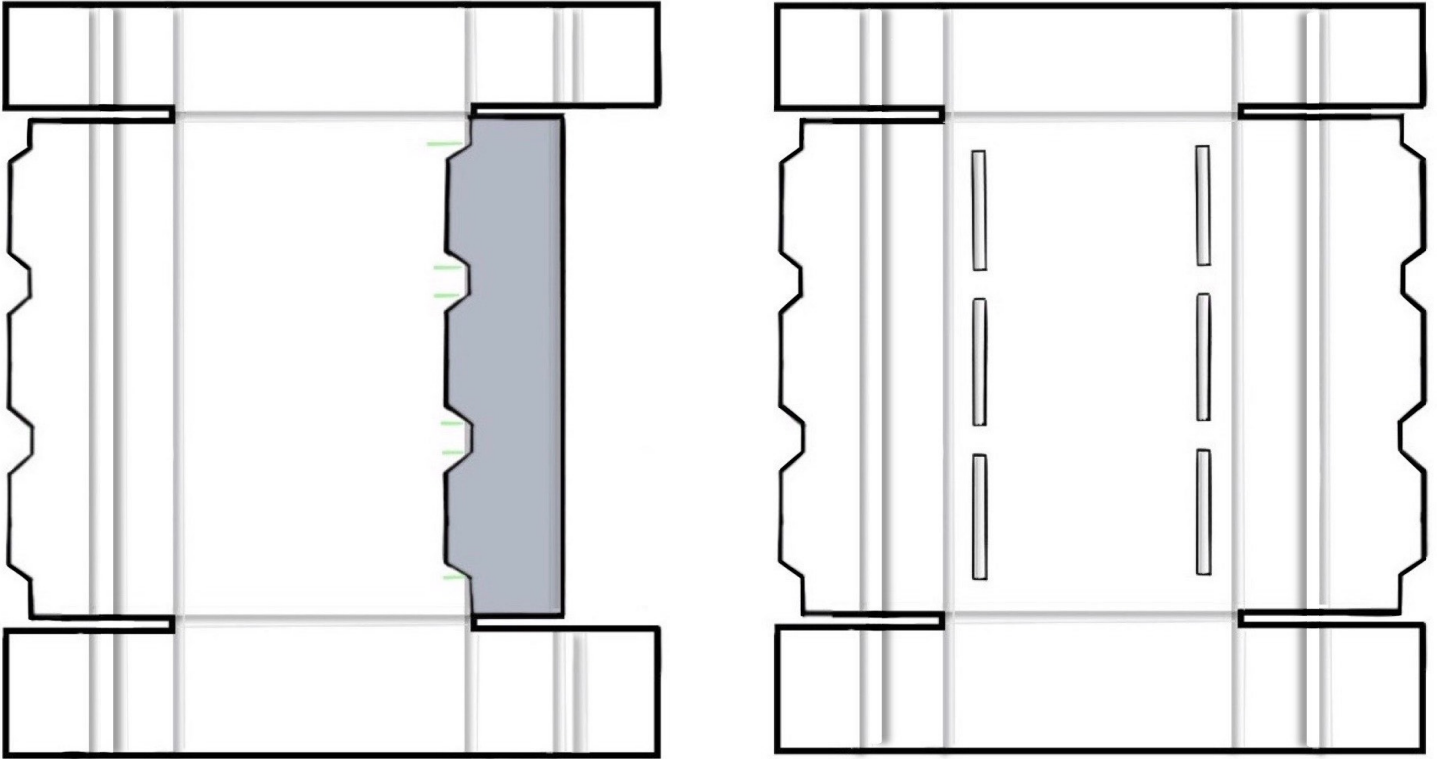

5. Fold over the top and bottom sides. The long edges will be tucked inside the left and right folds with tabs. Fold the left and right sides over the long edges and into the tabs.

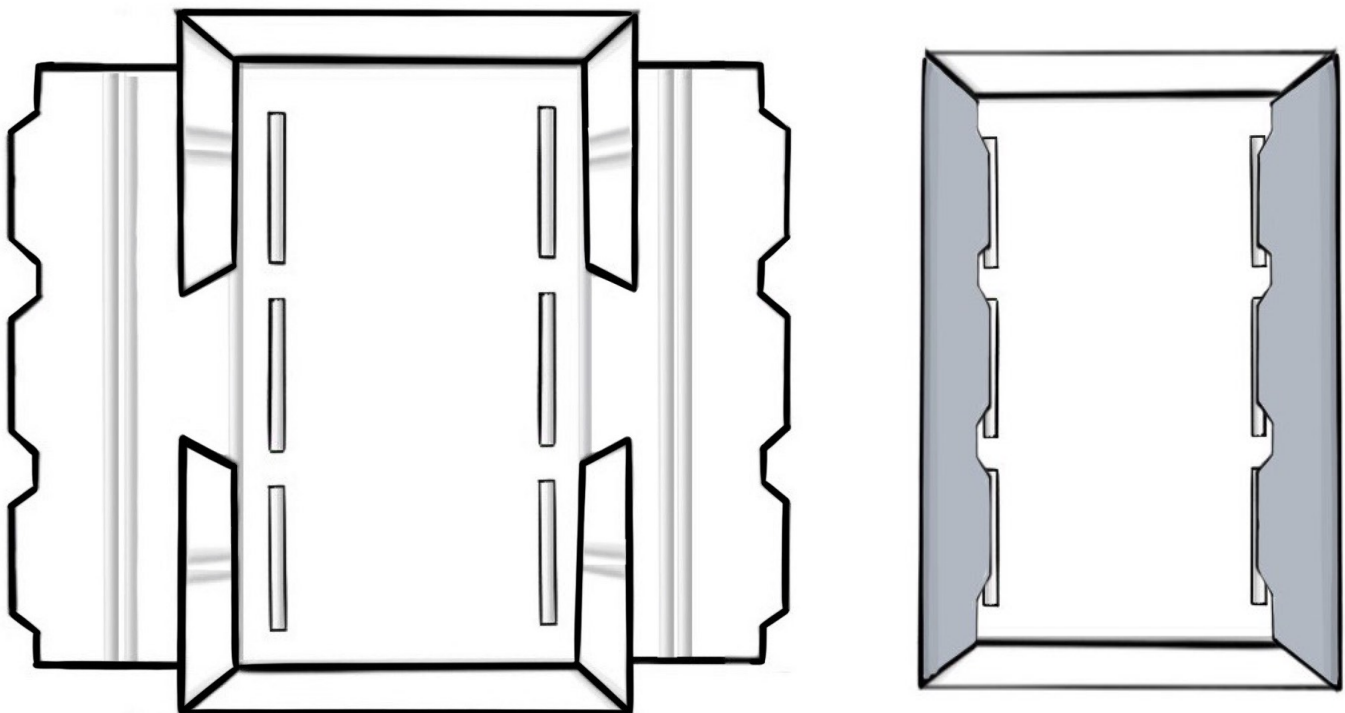

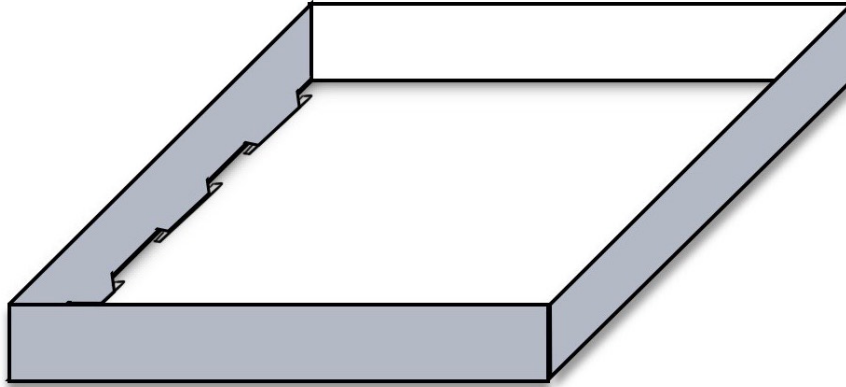

6. If either the lid or tray's tabs are sticking out, trim with a box cutter.

